

PAR/22010/01

IFC FIELD OF APPLICATION REPORT

Prepared For:	Royde & Tucker Ltd
Product/System:	HC605 Concealed Hinges
Assessed Performance:	30 and 60 minutes fire resistance
Fire Resistance Standard:	BS476: Part 22: 1987

This Document is the property of Royde & Tucker Ltd ©2021 all rights reserved. You MAY use this report for reference ONLY in relation to the specific purpose for which it was provided, but you MUST NOT print, copy or otherwise distribute it to any other party without the express written permission of Royde & Tucker Ltd.

International Fire Consultants Limited
Park Street Business Centre
Park Street
Princes Risborough
Buckinghamshire
HP27 9AH

Confidence in fire safety
www.ifcgroup.com

+44 (0)1844 275500
info@ifcgroup.com

INTERNATIONAL FIRE CONSULTANTS LIMITED

International Fire Consultants is part of the IFC Group. The company is a specialist engineering consultancy delivering independent, honest, and practical fire safety solutions to professionals across the built environment. The sought-after fire safety advice protects life, preserves property, and safeguards business continuity.

International Fire Consultants was established in 1985 to provide high quality and impartial technical expertise concerning fire safety. Since then the team of highly qualified Fire Engineers and Fire Safety Professionals have continued to deliver robust, innovative, and cost-effective fire safety solutions, including Assessments, Designs and Inspections.

International Fire Consultants are able to lend their insight and practical expertise for: **Fire Safety Engineering, Fire Risk Management, Product Evaluation, Fire Life Safety Systems, Expert Witness Testimony and Fire Protection Training**, to developments of all sizes and complexities; from residential, education and healthcare structures to sporting venues, airports and iconic heritage buildings, such as historical royal palaces and stately homes.

Recognised internationally as the go-to professionals in all aspects of fire safety, International Fire Consultants has a growing reputation as one of the world's leading fire engineering and solution providers, trusted by many of the most prestigious construction firms, architects and estate owners.

International Fire Consultants Limited

Park Street Business Centre
Park Street
Princes Risborough
Buckinghamshire
HP27 9AH
Registered No: 2194010

+44 (0)1844 275500
info@ifcgroup.com

Private and Confidential

This report should not be manipulated, abridged or otherwise presented without the written consent of International Fire Consultants Limited

Report Reference:	PAR/22010/01
Prepared For:	Royde & Tucker Ltd
Client Address:	Bilton Road Hitchin Hertfordshire SG4 0SB
Valid From:	May 2021
Valid To:	May 2026

ISSUE AND AMENDMENT RECORD

This Document is the property of Royde & Tucker Ltd ©2021 all rights reserved. You MAY use this report for reference ONLY in relation to the specific purpose for which it was provided, but you MUST NOT print, copy or otherwise distribute it to any other party without the express written permission of Royde & Tucker Ltd.

Revision	Date	Author	Reviewer	Section	Amendments
Draft	March 2021	WL	CPH	-	-
-	May 2021	WL	CPH	-	-

CONTENTS

1. INTRODUCTION.....	5
2. TEST EVIDENCE	6
3. SCOPE OF APPROVAL.....	7
3.1 Door Assemblies	7
3.2 Door Frames	11
4. ROYDE & TUCKER HC605 CONCEALED HINGE	12
5. CONCLUSION	14
6. LIMITATIONS.....	15
7. VALIDITY.....	16
8. DECLARATION BY THE APPLICANT	17
APPENDIX A SUMMARY OF FIRE TEST EVIDENCE	18

1. INTRODUCTION

This report has been prepared by International Fire Consultants Ltd (IFC), on the instruction of Royde & Tucker Ltd, to define the Field of Application for the HC605 concealed hinges when installed in particleboard door leaves installed in timber frames, that are required to provide 30 or 60 minutes fire resistance performance, when adjudged against BS476: Part 22: 1987.

This assessment has been produced using the principles outlined in the [Passive Fire Protection Forum \(PFPF\): 'Guide to Undertaking Technical Assessments of Fire Performance of Construction Products Based on Fire Test Evidence, 2021, Industry Standard Procedure'](#).

When establishing the variations in the construction that can achieve the required fire resistance performance, IFC complies with the principles found in the following documents:

- [BS ISO/TR 12470-2: 2017 'Fire resistance tests - Guidance on the application and extension of results from tests conducted on fire containment assemblies and products. Part 2: Non-load bearing elements'](#).
- [EN 15725: 2010: 'Extended application reports on the fire performance of construction products and building elements'](#).

It is proposed that variations to the tested specifications, as described in the following sections, may be accommodated by the HC605 concealed hinges, without reducing their potential to achieve a 30 or 60 minute integrity rating, if tested in accordance with the method and criteria of BS476: Part 22: 1987.

The omission of information on any components or manufacturing methods does not imply a lack of approval of those details, but these would need to be the subject of a separate analysis. Only variations specifically mentioned are supported by this assessment document, all other aspects must otherwise be as proven in tests summarised herein.

It is more onerous to test timber door assemblies, hinged, with the specimen installed with the leaf opening in towards the furnace. Testing in this orientation is therefore incorporated into Field of Application Reports to cover doors opening in the opposite direction. The principle is only applicable when the door construction, and any features within the door leaf, such as glazing, are symmetrical.

Unless stated otherwise, herein, this Field of Application considers the scope of approval for door assemblies that may be installed in either orientation, that being with either face exposed to fire conditions.

2. TEST EVIDENCE

The test evidence used to support this Field of Application Report is summarised in Appendix A of this report.

The test evidence referenced within this report has been carried out in accordance with BS EN 1634-1: 2014, whilst the scope of approval of this report is detailed if the door assemblies were tested to the fire test standard BS 476: Part 22: 1987. The appropriate performance of fire resisting door assemblies is defined in Approved Document B of the Building, the Scottish Building Standards Technical Handbook or the Building Regulations (Northern Ireland).

Approved Document B, which applies to England and Wales, identifies door assemblies by their performance under test to BS EN 1634-1 or BS476: Part 22: 1987, in terms of integrity for a period of minutes, (e.g. E30/E60, if their performance is measured in terms of EN 1634-1, or FD30/FD60 for BS476: Part 22: 1987). It should be noted that a suffix (S) is added for doors where restricted smoke leakage at ambient temperatures is needed. The Scottish and Northern Ireland documents also refer to the British and European Standards in Section 2D and Section B3 respectively of these documents.

These guidance documents thus give parity of performance between the two test methods, and although the EN 1634-1 and the BS476: Part 22: 1987 test procedures are both generally based upon the ISO 834 fire resistance test method, there are differences. These differences mean that the EN 1634-1 test is generally accepted as being a more onerous test than BS476: Part 22: 1987. This is borne out by IFC's experience of fire resistance testing already performed since the introduction of the European test standard.

As such, it is our opinion that any test results on door assemblies tested to EN 1634-1 can be utilised in situations requiring a performance defined against the BS476: Part 22 test method, or when making assessments and judgements against the BS476 criteria, but not vice versa.

3. SCOPE OF APPROVAL

3.1 Door Assemblies

Constructional specifications for the FD30 and FD60 door types that are permitted to be used with the Royde & Tucker HC605 concealed hinges can be found in the tables below.

Note that this Field of Application Report details the requirements of the door assemblies when installed with Royde & Tucker HC605 concealed hinges. All other aspects of door leaf constructions such as core and overpanel construction, glazing details, and hardware specifications are required to be within the limitations of the supporting Field of Application Report for that particular door type.

3.1.1 Configurations

General Requirements/Notes

- The table below provides an overview of the door configurations that are approved to be used when the door leaves are installed using the Royde and Tucker HC605 concealed hinges.
- The approved leaf configurations may be further restricted when specific design details, leaf/frame facings and/or hardware items are included, and the following supporting IFC Field of Application Reports should be referred to for complete design details.
 - The current revision of PAR/10341/01 – *Field of Application for 30 Minute 44mm Thick Halspan® Optima Door Leaves Installed in Timber, Aluminium and Steel Frames*
 - The current revision of IFCA/06166 – *Field of Application for 30 Minute 44mm Thick Halspan® Prima Door Leaves Installed in Timber, Steel and Aluminium Frames*
 - The current revision of IFCA/08037 – *Field of Application for FD30 Strebord® 44, Strebord® Superpan and Strebord® 54 Door Leaves Installed in Timber and Steel Frames*
 - The current revision of PAR/10341/02 – *Field of Application for 60 Minute 54mm Thick Halspan® Optima Door Leaves Installed in Timber Frames*
 - The current revision of IFCA/06167 – *Field of Application for 60 Minute 54mm Thick Halspan® Prima Door Leaves Installed in Timber and Steel Frames*
 - The current revision of IFCA/08038 – *Field of Application for FD60 Strebord® Door Leaves Installed in Timber and Steel Frames*

Configuration		Frame Material
Description	Code	Timber only
Latched, Single Acting, Single Leaf without Flush Overpanel	LSASD	✓
Unlatched, Single Acting, Single Leaf without Flush Overpanel	ULSASD	✓
Latched, Single Acting, Single Leaf with Flush Overpanel	LSASD+OP	✓
Unlatched, Single Acting, Single Leaf with Flush Overpanel	ULSASD+OP	✓
Latched, Single Acting, Double Leaf without Flush Overpanel	LSADD	✓
Unlatched, Single Acting, Double Leaf without Flush Overpanel	ULSADD	✓
Latched, Single Acting, Double Leaf with Flush Overpanel	LSADD+OP	✓
Unlatched, Single Acting, Double Leaf with Flush Overpanel	ULSADD+OP	✓

3.1.2 Maximum Assessable Door Leaf Sizes

This Field of Application Report is based on fire resistance tests conducted on door leaves that included the Royde & Tucker HC605 concealed hinge. In addition to this, the IFC Field of Application Reports that support the use of the door types approved for use with the Royde & Tucker HC605 concealed hinge are considered. These supporting Field of Application Reports are based on test reports which have been analysed using the empirically derived, non-construction specific methodologies which form the basis of IFC’s analysis. These methodologies allow the data obtained from the fire test evidence to be evaluated to determine permissible door leaf sizes, without any additional enhancements.

The calculated envelopes of assessed leaf dimensions for each door configuration covered by these supporting Field of Application Reports and approved for use with the Royde & Tucker HC 605 concealed hinge are given in the tables below.

Double door assemblies may each be of the same width, up to the maximum width indicated in the tables below. For unequal pairs, there is no limit on the ratio of leaf widths, (although the large leaf must still be within the limitations detailed herein). The width of the small leaf shall not be less than 250mm, since this will affect its vertical stability relative to that of the larger leaf.

FD30 Assemblies

Configuration	Maximum leaf size		
	Halspan® Optima	Halspan® Prima	Falcon® Strebord
LSASD	The current revision of PAR/10341/01	The current revision of IFCA/06166	Current Revision of IFCA/08037
ULSASD			
LSASD+OP			
ULSASD+OP			
LSADD	2203mm high x 926 + 926mm wide	2203mm high x 926 + 926mm wide	2203mm high x 926 + 926mm wide
ULSADD			
LSADD+OP			
ULSADD+OP			

It shall be ensured that the door leaf sizes permitted above are less than 120kg, the maximum weight permitted to be carried by the Royde & tucker HC605 concealed hinges.

FD60 Assemblies

Configuration	Maximum leaf size		
	Halspan® Optima	Halspan® Prima	Falcon® Strebord
LSASD	The current revision of PAR/10341/02	The current revision of IFCA/06167	The current revision of IFCA/08038
ULSASD			
LSASD+OP			
ULSASD+OP			
LSADD	2205mm high x 926 + 926mm wide	2205mm high x 926 + 926mm wide	2205mm high x 926 + 926mm wide
ULSADD			
LSADD+OP			
ULSADD+OP			

It shall be ensured that the door leaf sizes permitted above are less than 120kg, the maximum weight permitted to be carried by the Royde & tucker HC605 concealed hinges.

3.1.3 Core Construction - Leaf Thickness

Minimum Leaf Thickness	Maximum Leaf Thickness
44mm	54mm

Additional Requirements/Notes
<ul style="list-style-type: none"> It is permitted to utilise the 54mm thick FD60 cores referenced herein for 30 minute applications The installation of specific hardware items may necessitate an increase in leaf thickness. Refer to the appropriate supporting Field of Application Reports for full constructional details. The dimensions above exclude the thickness of the decorative leaf facings detailed in the relevant supporting Field of Application Reports.

3.1.4 Core Construction - Leaf Core Products

Require Fire Resistance	Material	Minimum Density	Dimensions
30 minutes only	Halspan® Optima	620kg/m ³	44mm thick
30 minutes only	Halspan® Prima	630kg/m ³	44mm thick
30 minutes only	Falcon® Strebord	520kg/m ³	44mm thick
30 or 60 minutes	Halspan® Optima	620kg/m ³	54mm thick
30 or 60 minutes	Halspan® Prima	630kg/m ³	54mm thick
30 or 60 minutes	Falcon® Strebord	520kg/m ³	54mm thick

Additional Requirements/Notes
<ul style="list-style-type: none"> A variation of ±10% is permitted on the minimum core density detailed above Full details of the leaf core requirements shall be referenced in the following supporting Field of Application Reports. <ul style="list-style-type: none"> The current revision of PAR/10341/01 – <i>Field of Application for 30 Minute 44mm Thick Halspan® Optima Door Leaves Installed in Timber, Aluminium and Steel Frames</i> The current revision of IFCA/06166 – <i>Field of Application for 30 Minute 44mm Thick Halspan® Prima Door Leaves Installed in Timber, Steel and Aluminium Frames</i> The current revision of IFCA/08037 – <i>Field of Application for FD30 Strebord® 44, Strebord® Superpan and Strebord® 54 Door Leaves Installed in Timber and Steel Frames</i> The current revision of PAR/10341/02 – <i>Field of Application for 60 Minute 54mm Thick Halspan® Optima Door Leaves Installed in Timber Frames</i> The current revision of IFCA/06167 – <i>Field of Application for 60 Minute 54mm Thick Halspan® Prima Door Leaves Installed in Timber and Steel Frames</i> The current revision of IFCA/08038 – <i>Field of Application for FD60 Strebord® Door Leaves Installed in Timber and Steel Frames</i>

3.1.5 Timber Door Lippings – General

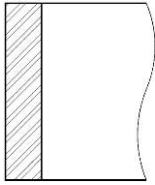
Material	Minimum Density	Minimum Thickness	Profile	Lipping Adhesive
Hardwood	640kg/m ³	6mm		<ul style="list-style-type: none"> • Urea formaldehyde • Phenol formaldehyde • PU

Additional Requirements/Notes
<ul style="list-style-type: none"> • Lippings must be installed to both vertical leaf edges • There must be no gaps present between the core and lippings • All other lipping requirements shall be as per the supporting Field of Application Reports referenced herein.

3.2 Door Frames

3.2.1 Timber Door Frames – Specifications and Profiles

The following door frame specification shall take precedence over the supporting Field of Application Reports for the door types approved herein for 30 and 60 minutes fire resistance performance, when using the Royde & Tucker HC605 concealed hinges.

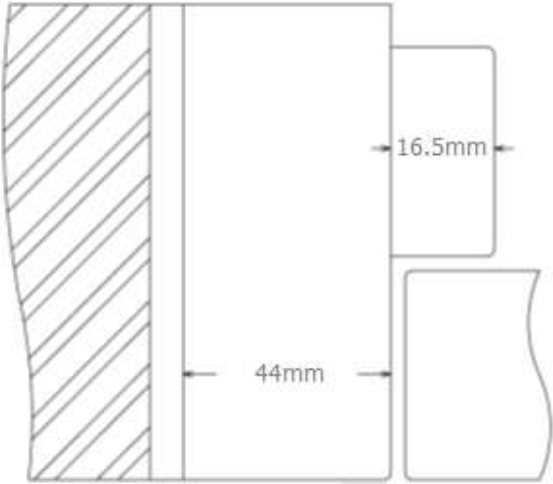
Timber frames for 30 and 60 minutes fire resistance		
	Frame Material	Hardwood (excluding Beech)
	Minimum Density	640kg/m ³
	Minimum Thickness	44mm
	Minimum Frame Depth	94mm
	Minimum Stop Depth	16.5mm
	Additional Requirements/Notes	
<ul style="list-style-type: none"> • The minimum frame thickness detailed above excludes the door stop • The doorstop is to comprise the same material as the door frame and must be fixed in place using 40mm long steel pins • Timber must have a minimum measured density at 12% moisture content. The timber must be straight grained and of appropriate quality in accordance with BS EN 942: 2007. The moisture content shall be 11 ± 2% for the UK market, (or to suit internal joinery moisture content specification of export countries). • The frame shall include 2no 15 x 4mm graphite based intumescent seals 10mm apart and 8mm from the exposed edge. Seals shall be selected from the types approved for use in the supporting Field of Application Reports for the door type. 		

4. ROYDE & TUCKER HC605 CONCEALED HINGE

The Royde & Tucker HC605 concealed hinge may be used in the door assemblies approved by this report. Full details of the HC605 concealed hinge and its installation requirements are included below.

Element	Specification/Quantity/Dimensions	
Approved Door Frame Material	Timber (Hardwood only – excluding beech)	
Minimum Number of Hinges & Positions	<ul style="list-style-type: none"> • 2no. for leaves up to 2200mm high • 3no. for leaves greater than 2200mm high • Top hinge to be fitted 250mm from the head of the door leaf to the hinge centre • Bottom hinge to be fitted 250mm from the bottom edge of the door leaf to the hinge centre • When required, the centre hinge shall be fitted equispaced between the top and bottom hinge or 435mm from the top hinge measured from the centre of each hinge body (in frame) • Set back 3mm from the exposed face of the leaf and 20mm from the exposed face of the frame 	
Hinge Body (Door)	185mm high x 32.5mm wide x 32.3mm deep	
Hinge Body (Frame)	119.5mm high x 22mm wide x 4.8mm deep	
Material	Stainless steel	
Fixings	<ul style="list-style-type: none"> • 4no. 4.8mm diameter x 80mm long stainless steel countersunk screws per blade in the leaf • 4no. 4.7mm diameter x 31mm long stainless steel countersunk screws per blade in the frame 	
Intumescent Protection	Hinge Body	1mm thick Interdens wrapped around the body of leaf portion.
	Bottom of Hinge Mortices	2mm thick Interdens fitted under the leaf portion body and under the face plate (leaf and frame portion)
Additional Requirements/Notes	<ul style="list-style-type: none"> • The mortices for the hinges in the door leaf and frame must be cut tightly, such that there are no gaps around the hinge components/intumescent material when the hinges are installed. • It must be ensured that the correct number of hinges are fitted to ensure that the door leaf is supported for the full fire resistance period. 	

Figures

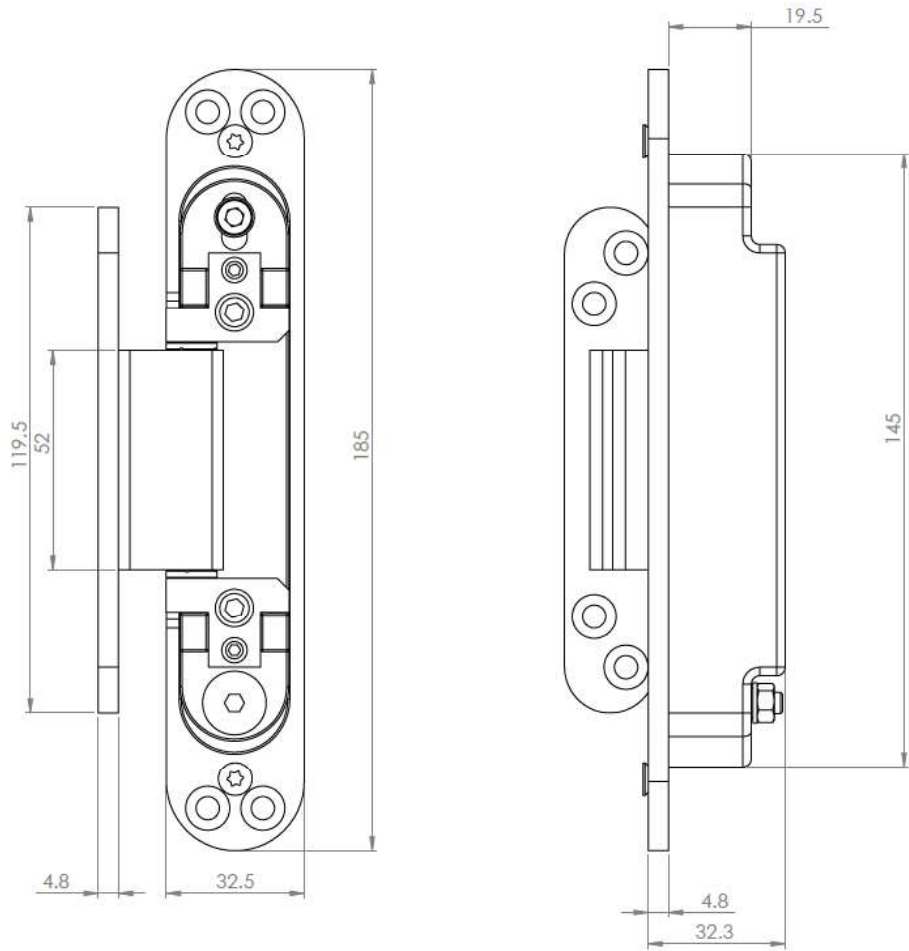

5. CONCLUSION

It is the opinion of International Fire Consultants Ltd that if the proposed Royde and Tucker HC605 concealed hinges were manufactured and installed within the limitations of this Field of Application Report and tested for fire resistance, they would provide a positive contribution to the door assemblies in meeting the integrity criteria of BS476: Part 22: 1987 for 30 or 60 minutes, as applicable.

6. LIMITATIONS

This report addresses itself solely to the ability of the proposed assemblies described to satisfy the criteria of the fire resistance test and does not imply any suitability for use with respect to other unspecified criteria.

This document only considers the door assemblies described, herein, and assumes that the surrounding construction will provide no less restraint than the tested assembly and that it will remain in place and be substantially intact for the full fire resistance period.

This report is issued on the basis of test data and information to hand at the time of issue. If contradictory evidence becomes available, IFC reserves the right to withdraw the report unconditionally but not retrospectively.

Where the constructional information in this report is taken from details provided to International Fire Consultants Ltd (IFC) and/or from fire resistance test reports referenced herein, it is, therefore, limited to the information given in those documents. It is necessarily dependent upon the accuracy and completeness of that information. Where constructional or manufacturing details are not specified, or discussed, herein, it should not, therefore, be taken to infer approval of variation in such details from those tested or otherwise approved.

The analysis and conclusions within this report are based upon the likely fire resisting performance of a complete door assembly that is manufactured and installed in accordance with this document and offered for fire resistance testing in 'perfect' condition. In practice, management procedures must be in place in any building where the door assemblies are installed, to ensure that no parts of the assembly are damaged or faulty. Further, the doors must open and close without the use of undue force. The edge gaps/alignment of door leaves must be in accordance with the tolerances defined, herein, when the doors are closed. Any such shortfalls in respect to the condition of the assemblies will invalidate the approval by IFC, and may seriously affect the ability of the assemblies to provide the required level of fire resistance performance. Determination of what constitutes wear or damage, and any corrective actions in order to return assemblies to the required condition, should only be carried out following consultation with the manufacturer and IFC.

This report applies to fire door assemblies that are evaluated to BS476: Part 22: 1987; which is an applicable test method currently referenced within guidance to Building Regulations in the United Kingdom, and in building codes in some other countries. However, IFC have a duty of care to advise that introduction of CE Marking may become compulsory for fire resisting doorsets marketed in the EU, during the validity period of this report; in which case, users should contact IFC for further details/advice.

Where the assessed constructions have not been subject to an on-site audit by International Fire Consultants Ltd, it is the responsibility of anyone using this report to confirm that all aspects of the assemblies fully comply with the descriptions and limitations, herein.

Any materials specified in this report have been selected and judged primarily on their fire performance. IFC do not claim expertise in areas other than fire safety. Whilst observing all possible care in the specification of solutions, we would draw the reader's attention to the fact that during the construction and procurement process, the materials used should be subjected to more general examination regarding the wider Health and Safety, and CoSHH Regulations. Designers, manufacturers and installers are reminded of their responsibilities under the CDM Regulations; but particularly with regard to installation and maintenance of heavy or inaccessible items.

This assessment considers the fire resistance performance of the door assemblies when tested with the leaves in the closed position, within the frame reveal; either retained by the latch, or self-closing device or locked shut, as applicable. The door assemblies will only provide the assessed fire performance when in a similar configuration; and it is the responsibility of the building occupants/owner to ensure that this is the case.

This report is provided to the sponsor on the basis that it is a professional independent engineering opinion as to what the fire performance of the construction/system would be should it be tested to the named standard. It is IFC's experience that such an opinion is normally acceptable in support of an application for building approvals, certainly throughout the UK and in many parts of Europe and the rest of the world.

However, unless IFC have been commissioned to liaise with the Authorities that have jurisdiction for the building in question for the purpose of obtaining the necessary approvals, IFC cannot assure that the document will satisfy the requirements of the particular building regulations for any building being constructed.

It is, therefore, the responsibility of the sponsor to establish whether this evidence is appropriate for the application for which it is being supplied and IFC cannot take responsibility for any costs incurred as a result of any rejection of the document for reasons outside of our control. Early submittal of the Report to the Authorities will minimise any risks in this respect.

7. VALIDITY

This Field of Application Report has been prepared based on International Fire Consultants Ltd's present knowledge of the products described, the stated testing regime and the submitted test evidence. For this reason, anyone using this document after March 2026 should confirm its ongoing validity.

This Field of Application Report is not valid unless it incorporates the declaration by the applicant given in Appendix A duly signed by the applicant.

Prepared by:



Will Lightfoot

BEng (Hons) MSc AIFireE
Senior Fire Safety Engineer
International Fire Consultants Ltd. (IFC)

Reviewed by:



Chris Houchen

BSc. AIFireE
Associate Director
International Fire Consultants Ltd. (IFC)

This Document is the property of Royde & Tucker Ltd ©2021 all rights reserved. You MAY use this report for reference ONLY in relation to the specific purpose for which it was provided, but you MUST NOT print, copy or otherwise distribute it to any other party without the express written permission of Royde & Tucker Ltd.

8. DECLARATION BY THE APPLICANT

IFC Engineering Assessment Report	PAR/22010/01
Client	Royde & Tucker Ltd

We, the undersigned, confirm that we have read and complied with the obligations placed on us by the Passive Fire Protection Forum (PFPF), details of which are outlined in the following document;

Passive Fire Protection Forum (PFPF) - Industry Standard Procedure 2021
'Guide to Undertaking Technical Assessments of Fire Performance of Construction Products Based on Fire Test Evidence'

- We agree to withdraw this assessment from circulation should the component or element of structure, or any of its component parts be the subject of a failed fire resistance test to the standard against which this assessment is being made.
- We understand that this assessment is based on test evidence and will be withdrawn should evidence become available that causes the conclusion to be questioned. In that case, we accept that new test evidence may be required.
- We are not aware of any information that could affect the conclusions of this assessment. If we subsequently become aware of any such information, we agree to ask International Fire Consultants Ltd (IFC) to withdraw the assessment.

Signature	
Name	
Position	
Company name	Royde & Tucker Ltd
Date	

This Document is the property of Royde & Tucker Ltd ©2021 all rights reserved. You MAY use this report for reference ONLY in relation to the specific purpose for which it was provided, but you MUST NOT print, copy or otherwise distribute it to any other party without the express written permission of Royde & Tucker Ltd.

APPENDIX A SUMMARY OF FIRE TEST EVIDENCE

Test Report	Test Sponsor	Test Lab	Test Date	Config	Leaf Size	Test Standard	Result	Items/Details Supported by Test Evidence
CFR1710131 Door A	Royde & Tucker Ltd	Cambridge Fire Research	13.10.2017	ULSASD	2203mm X 926mm X 54mm	BS EN 1634-1:2014	48 minutes	<ul style="list-style-type: none"> Royde & Tucker 605 concealed hinges installed within a 54mm thick leaf
<p>*The premature integrity failure at 48 minutes was caused by ignition of a cotton pad at the top closing corner of the leaf. Further flaming occurred at the head of the leaf at 53 minutes and bottom of closing edge at 58 minutes. No failure was recorded at the hinge locations prior to 66 minutes. Test CFR1711241 Door A summarised below demonstrates the successful test of a 54mm thick leaf including the HC605 concealed hinges for 60 minutes fire resistance.</p>								
CFR1710131 Door B	Royde & Tucker Ltd	Cambridge Fire Research	13.10.2017	ULSASD	2203mm x 926mm x 44mm	BS EN 1634-1:2014	38 minutes	<ul style="list-style-type: none"> Royde & Tucker 604 concealed hinges installed within a 44mm thick leaf
CFR1711241 Door A	Royde & Tucker Ltd	Cambridge Fire Research	24.11.2017	ULSASD	2205mm x 926mm x 54mm	BS EN 1634-1:2014	68 minutes	<ul style="list-style-type: none"> Royde & Tucker 605 concealed hinges installed within a 54mm thick leaf