

# D141-S-R-SD Damper Fitting / Setup Instructions

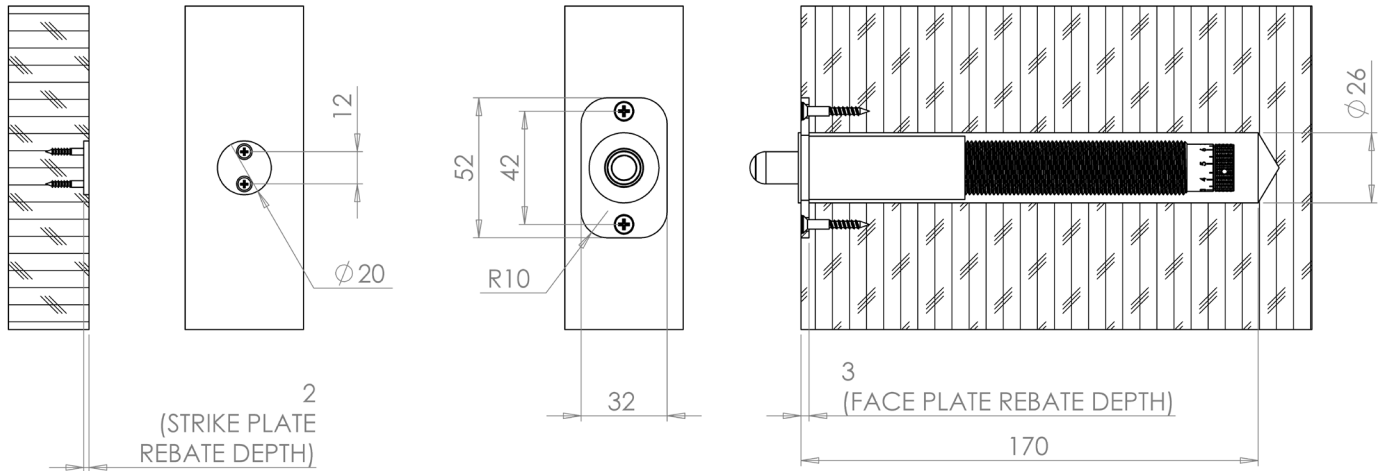

## Step 1

Rebate the door and frame to match the details shown.



## Step 2

Fit the strike plate and damper unit with the screws provided.

Release the door from the fully open position. Correctly damped, the door will gently come to the closed condition with no bounce.

If necessary, remove the unit from the door to adjust the damping.

- Loosen the lock screw with the 1.5mm hex allen key provided.
- Rotate the adjusting knob to change the damping force. Use the red dot on the adjusting knob for reference.
- Tighten the lock screw and refit the unit to the door to test.

Repeat as necessary until correct damping action is achieved.

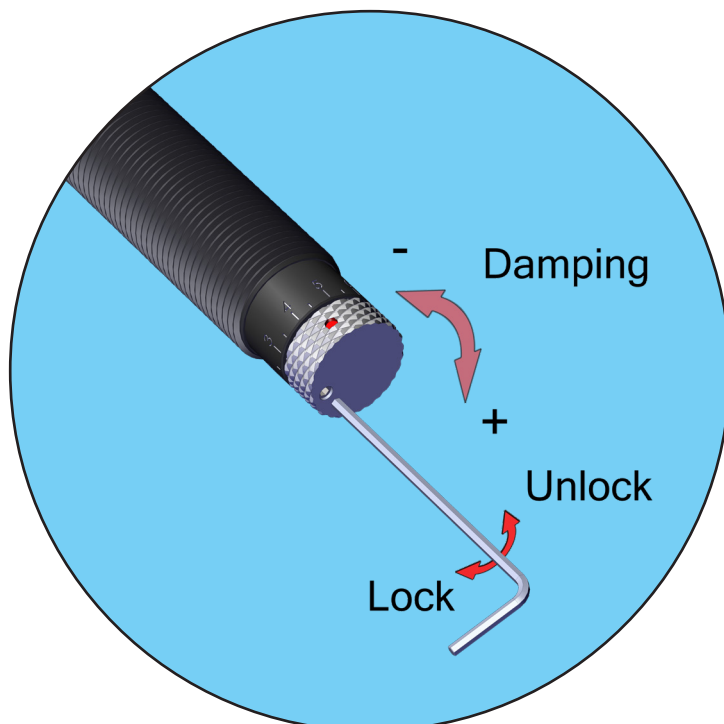

For further information please visit our website.



Royde & Tucker Ltd.  
Bilton Road, Cadwell Lane  
Hitchin. SG4 0SB  
Tel: 01462 444 444  
Email: [sales@ratman.co.uk](mailto:sales@ratman.co.uk)  
[www.ratman.co.uk](http://www.ratman.co.uk)