

Royde & Tucker D140 (D140-R) Hydraulic Damper unit

STRIKER PLATE INSTALLATION

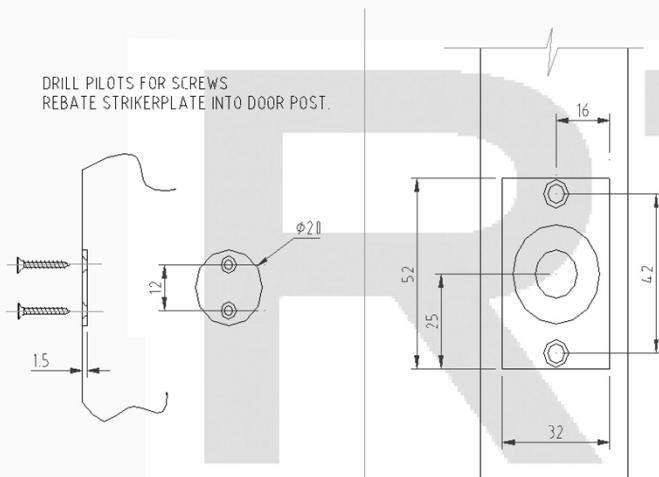

NOTE: PLACE STRIKER PLATE ON DOOR POST, SO THAT THE PLUNGER OF THE DAMPER MOUNTING BEARS ONTO IT AS THE DOOR CLOSES.

DAMPER INSTALLATION

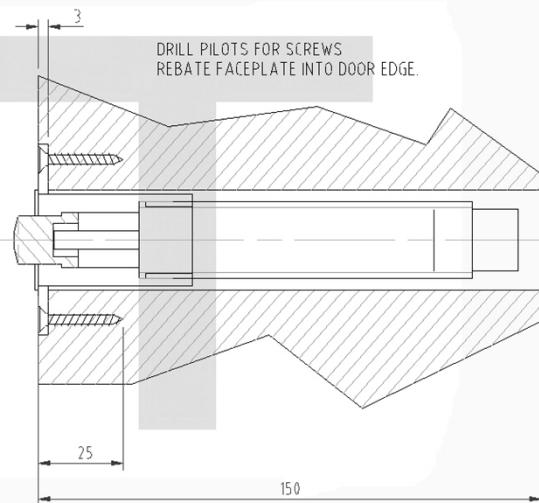

NOTE: ENSURE THAT THE HOLE FOR THE DAMPER IS PARALLEL WITH THE FACE OF THE DOOR TO AVOID DAMAGE TO THE FACING MATERIAL. THE 26Ø HOLE SHOULD BE PLACED SO THAT THE FACEPLATE DOES NOT PROTRUDE BEYOND THE EDGE OF THE DOOR, BUT IS AS FAR AWAY FROM THE HINGE KNUCKLE CENTRELINE AS POSSIBLE TO GIVE MAXIMUM MECHANICAL ADVANTAGE. ADJUST THE DAMPER FORCE BY TURNING THE KNOB AT THE BASE OF THE UNIT

- 144x52x32mm Damper unit for use with rising butt hinges
- Dampens the closing action between 26° and 0° on a 44mm door using a RT H300 series hinge
- Adjustable power. Slacken locking nut with 1.5mm Alan key, turn knob on base of unit, towards 0 for less resistance, towards 9 more resistance; re-fit.
- Unit is mounted in the hinge edge of the door (frame or door mounted). Should be positioned in close proximity to one of the rising butts
- Available with 10mm radii to faceplate (D140-R)

Notes:

If door mounting, ensure that the unit's bore hole is parallel to the door face.

Placing the unit further from the hinge pivot point gives maximum mechanical advantage

The units faceplate and strike plate must be flush mounted

Royde & Tucker Ltd

Bilton Road

Cadwell lane

Hitchin

SG4 0SB

Tel: 01462 444444

Fax: 01462 444433

www.ratman.co.uk

e-mail: sales@ratman.co.uk